

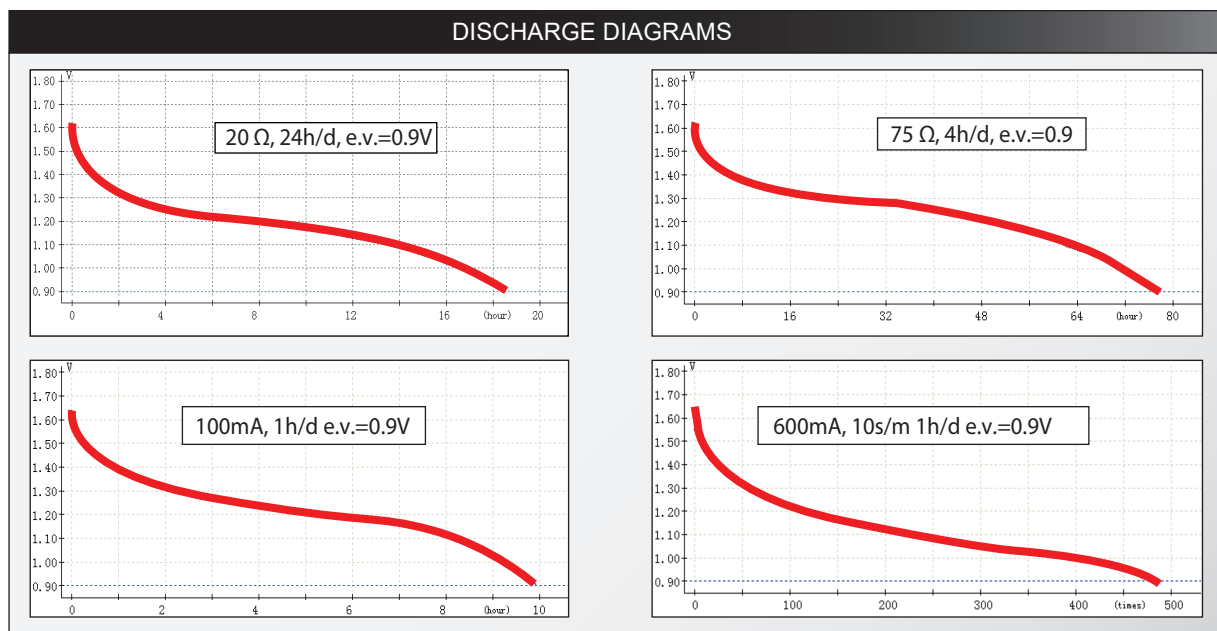

SPECIFICATION	
DESIGNATION	LR03/AAA
NOMINAL VOLTAGE	1.5V
TYPICAL CAPACITY	1320mAh
TYPICAL WEIGHT	12.0g
TYPICAL VOLUME	3.8cm ³
TERMINALS	Flat Contact
CHEMICAL SYSTEM	Alkaline Zinc-Manganese dioxide
STORAGE TEMPERATURE RANGE	<30°C
OPERATING TEMPERATURE RANGE	-18°C~50°C

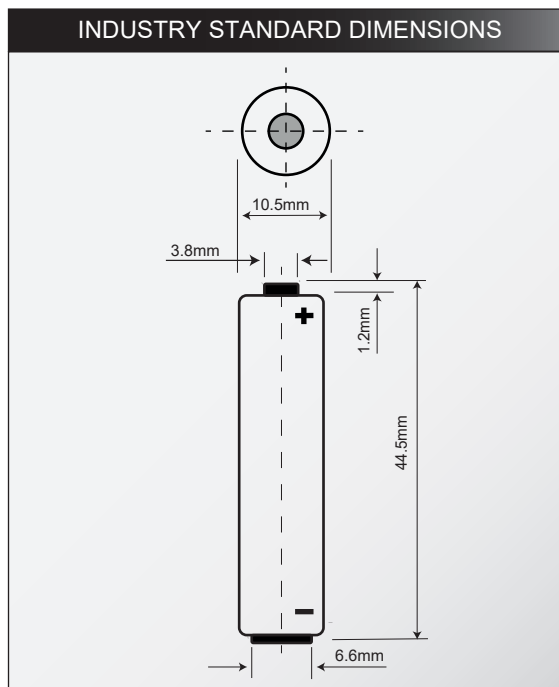

STANDARDS

EN 60086-1:2021 and EN 60086-2:2021 – Primary Batteries – Safety of batteries with aqueous electrolyte

Important Notice

This specification contains typical information specific to products manufactured at the time of publication. The data is subject to change and should be used for reference only. Contact FujiEnergy for the latest information.