

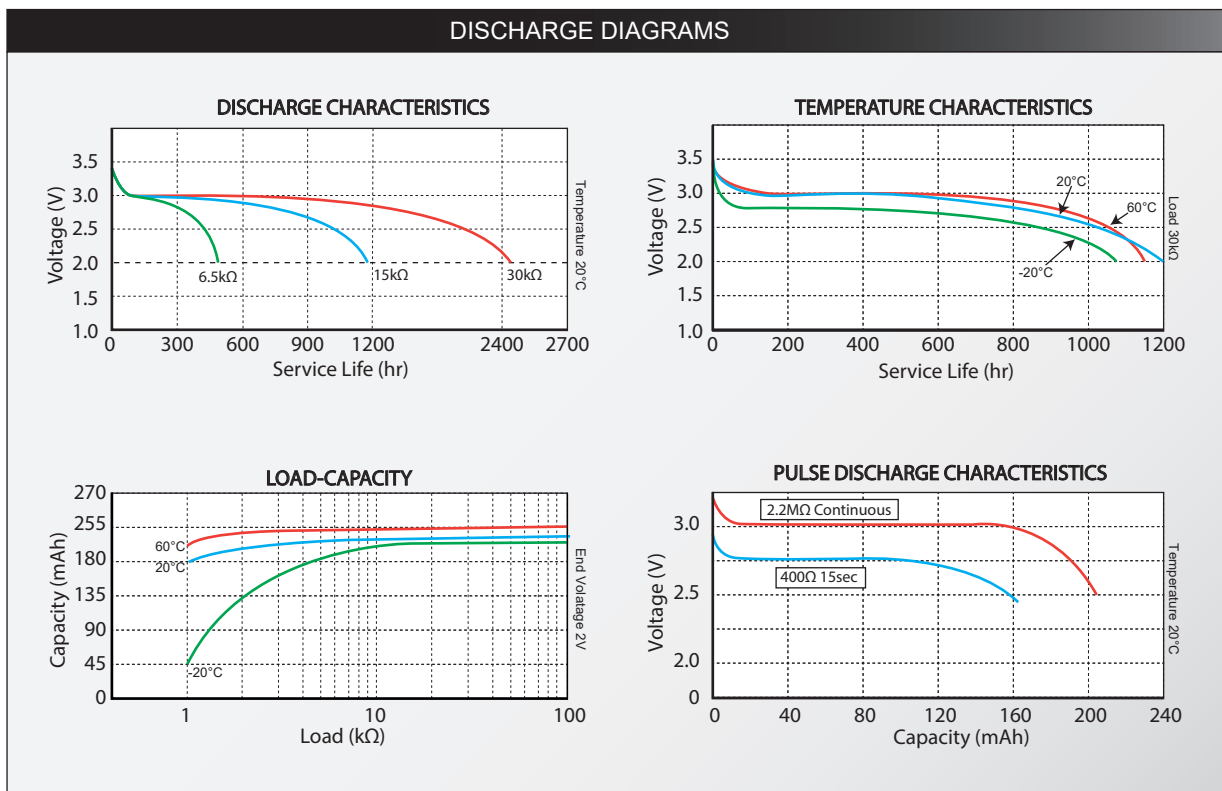

SPECIFICATION	
DESIGNATION	CR2032
NOMINAL VOLTAGE	3.0V
TYPICAL CAPACITY	210mAh
TYPICAL WEIGHT	2.75g
TYPICAL VOLUME	1.0cm ³
INSTANT SHORT-CIRCUIT CURRENT	≥250mA
CHEMICAL SYSTEM	Lithium Manganese Dioxide
SELF-DISCHARGE RATE	≤1% per year
OPERATING TEMPERATURE RANGE	-20°C~60°C

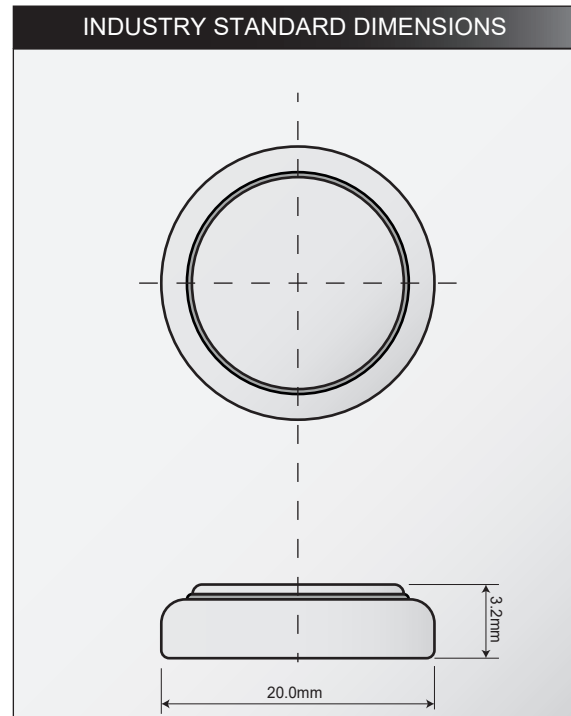

PREPARED BY	CHECKED BY	APPROVED BY

Important Notice

This specification contains typical information specific to products manufactured at the time of publication. The data is subject to change and should be used for reference only. Contact FujiEnergy for the latest information.